

RELIABILITY MODEL OF BEARING ASSEMBLY ON AN AGRICULTURAL CARDAN SHAFT

E. DESNICA^a, A. ASONJA^{b*}, D. MIKIC^b, B. STOJANOVIC^c

^a *Technical Faculty 'Mihajlo Pupin', University of Novi Sad,
Djure Djakovica Blvd, Zrenjanin, Serbia*

^b *The Serbian Academic Centre, 18/31 Stevana Mokranjca, Novi Sad, Serbia
E-mail: aleksandar.asonja@gmail.com*

^c *Faculty of Engineering, University of Kragujevac, 6 Sestre Janjic Street,
Kragujevac, Serbia*

ABSTRACT

The mechanism that is discussed in this study is cardan shaft. The main objective of the proposed and completed research within the presented work was diagnostic of bearing assembly at joints of cardan shafts, which was performed in order to define the overall reliability of shafts. Presented reliability model of cardan shafts is based on an examination of diagnostic size of the bearing assembly on cardan joints. This document presents a difference between reliability of cardan shafts investigated in pure laboratory conditions and those cardan shafts investigated in clean exploitation conditions.

Keywords: model, reliability, cardan shaft, cardan joints, bearing sets/assembly.

AIMS AND BACKGROUND

Cardan shaft is widely used in various types of industrial and transport machinery. Elements of the driveshaft are burdened with a combined stress in bending, torsion, shear and surface pressure. During operation, due to overloading may cause various destruction of materials and fracture of shaft parts¹. There are four ways to transfer power (mechanic, hydraulic, electric and pneumatic), from tractors to implements but in practice, the most common are mechanic and hydraulic transmission. For now, the mechanical transmission is far more prevalent than hydraulic. Mechanical power transmission system for agricultural machinery is

* For correspondence.

carried out directly with belt pulleys, sprockets, gears, cardan shafts or flexible shafts².

Driveshafts still have an important role in the transmission of torque from the driven machine (tractor) to agricultural machines. Today, on almost all the implements of agriculture (presses, planters, fertilizer spreader, potato diggers, etc.) torque and power of the tractor is mainly transmitted mechanically through the cardan shaft³.

The service life of drive gears for agricultural machinery, tractors and other equipment that uses the universal transfer, is limited with the disruption of work ability of cardan joints in 80~90% of cases. All of this is conditioned with an allowed increase of axial and radial clearance and circular clearance and the ring (including needle) gap junctions in the universal joint (outer radial branch of the cross of shaft and needle bearing as well as needle bearing and the opening cups with forks).

Basic forms of reduced reliability of cardan transmission (in terms of correct choice of the size of shaft and exclusion from consideration of corrosion and surface damage and failures conditioned by the rough errors in the production and exploiting), are surface materials fatigue and abrasive wear in 41% cases, and formation of longitudinal, often steep, oblique depressions caused by the effect of so-called 'Brinelling' (plastic deformation) in 45% cases. According to today studies of agricultural machinery 14% failure of the mechanical gear go to the cardan transmission, and on them were about 60% represented failures of cardan joints⁴.

Some examples of reduced reliability of shafts are shown in Fig. 1. Figure 1a shows the damaged double cardan shaft, which fatally wounded the 61-year-old truck driver. The deceased worker tried to turn on the shaft, which was used to operate the pump on tank, however, shaft detached from one of its joints⁵. Another example of fatal injuries that occurred in unprotected double cardan shaft in agriculture in Italy is shown in Fig. 1b (Ref. 6).

Fig. 1. Examples of the possible occurrence of hazards on a double cardan shafts: *a* – the damaged shaft on a truck with tank, and *b* – the damaged shaft on agricultural tractor

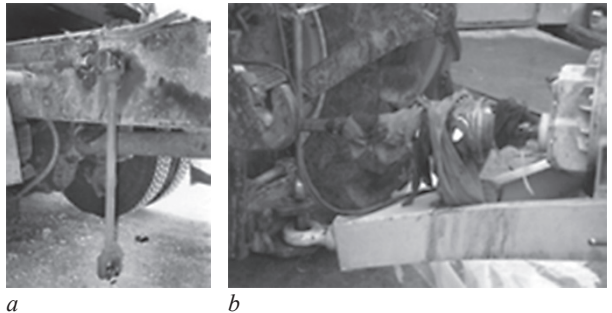

EXPERIMENTAL

Reliability testing was performed on double agricultural cardan shafts under laboratory and operating conditions. In this experiment we used size I of the double cardan shaft. We used Z workmanship cardan shafts, with rotation angle of 20° (Fig. 2). In Fig. 3 is shown the testing of the universal joint in the work, which consists of five operating elements: needle bearings, cross, cups, lubricant and sealant.



Fig. 2. 3D image of a double cardan shaft



Fig. 3. 3D image of cardan joints

The total number of examined double agricultural cardan shafts was three experimental samples and three laboratory samples. Laboratory shaft samples, i.e. diagnostics testing of bearing sets on them were investigated at all times in only laboratory conditions in the next 304 h of work, while the exploitation samples tested in practical use until they reached the limit condition according to a previously established criteria. Average use time of tested exploitation samples was 139 h, after which they were taken away to the laboratory test tables where were examined their diagnostic parameters in pre-failure condition. Presented parameters of diagnostic testing (temperature and axial acceleration of vibration) at bearing sets on cardan joints, pointed out how each of these parameters individually or both together affect the reliability level of bearing sets on cardan joints, respectively and the reliability of the drive shafts. Mean values of time for individual diagnostic parameters were calculated, respectively defined using the appropriate mathematical function, which will by appropriate mathematical functions reach limit states observed diagnostic size. Reliability models presented in the form of technical diagnostics were created based on discovered laws of movements of measured diagnostic parameters on laboratory samples examination, and finally copied to the exploitation test sample, resulting in a difference in the apparent movement of the reliability.

Before beginning of the test we started from the hypothesis that the reliability of double agricultural shafts in operation, with 20° rotation angle of joints, is significantly lower than reliability of shafts examined in laboratory.

In this work, from dynamic testing method reliability of shafts, are used dynamic methods for monitoring vibration (velocity and acceleration) and temperature in the cardan joints and study method of rev number on the cardan shaft.

Diagnostics of rolling bearings in the bearing sets (assemblies) is conducted on the joints of shafts and fixed bearings on the drive and the driven shaft. On the fixed bearing units, which are closer to driveshaft joints, i.e. those who are at the end of the shaft on which they are attached, are done examinations, which values are actually values of vibrations in bearing sets (assemblies) of cardan joints.

The instruments used for measurement were as follows:

- Marlin probe SMVL 3600 IS – for measuring vibration levels;
- Laser Infrared Thermometer – for monitoring temperature;
- Probator for measuring number of revolutions.

Criteria for evaluation of bearing sets according to the vibration parameters were performed according to the standard ISO 10816-1:1995/AMD, whereas the criteria for evaluation of temperature were carried out according to the parameters in Table 1.

Table 1. Limit value assessment of the condition of bearing set on cardan joints depending on their temperature

Bearing temperature (°C)	Bearing condition
< 62	satisfying condition
62÷73	unsatisfying condition (warning)
> 73	undesirable condition

RELIABILITY MODEL USED IN EXAMINATION

In the reliability analysis of bearing sets on cardan shaft were used the following diagnostic parameters: temperature, axial acceleration of vibration and axial speed of vibration. Parameters of axial speeds significantly deviate from parameters of temperature and axial acceleration of vibration, because of that, it has been left out from constructing the reliability model of cardan shafts.

Reliability models presented in the form of technical diagnostics were created based on discovered laws of movements of measured diagnostic parameters on laboratory samples examination, and finally copied to the exploitation test sample, resulting in a difference in the apparent movement of the reliability. It is clear that the difference was large and it was created as a result of the poor conditions of technical maintenance, improper use and complex operating conditions prevailing in agricultural production.

The reliability model observed through diagnostic testing parameters (temperature and axial acceleration) of bearing sets on cardan joints pointed out how

each of these parameters, both individually and together, affect the reliability level of cardan joints, respectively on the reliability of the double cardan shafts. According to the proposed reliability model, based on a permanent diagnostics of bearing sets and especially adequate maintenance of laboratory samples of examined shafts, the existing service life duration, respectively cardan joints, shafts would significantly increase.

LABORATORY STAND

For research purposes experimental table has been designed and produced, ‘ANA’ type, model 23-26-26-04, which is primarily intended for testing the reliability of agricultural shafts, however, it can also be used for testing other shafts and other mechanical power transmission^{7,8}.

The main components of this laboratory table, which were conducted reliability testing of shafts (Fig. 4), are:

- 1 – steel frame (base);
- 2 – main electrical control box for the power supply of electric motors and control systems for load;
- 3 – driving portion (electric motor);
- 4 – belt conveyors in the driven section;
- 5 – bearing units on the first assistant shaft;
- 6 – first side shaft;
- 7 – accumulators (batteries);
- 8 – test cardan shaft;
- 9 – DC generator of direct current;
- 10 – bearing units on the second auxiliary shaft;
- 11 – second side shaft;
- 12 – belt conveyors on the brake part;

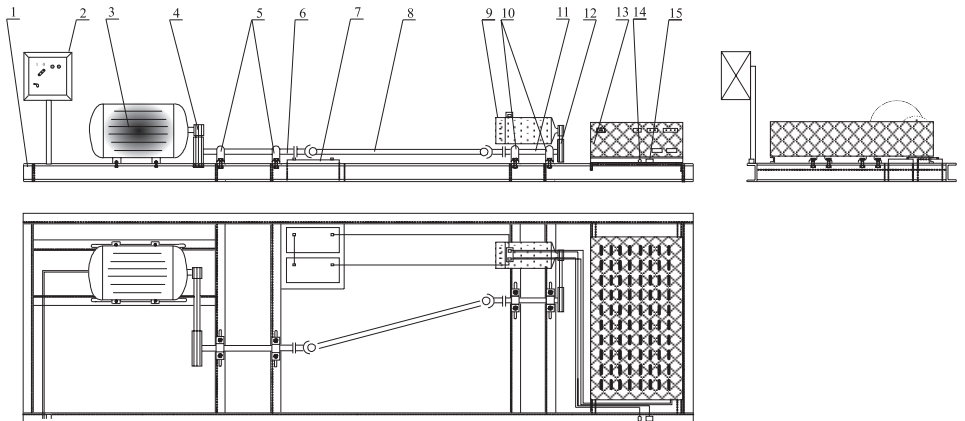

Fig. 4. Schematic view of the laboratory stand ‘ANA’ for testing the reliability of cardan shaft

- 13 – system for controlling load;
- 14 – manual control of generator excitation DC;
- 15 – control lamp excitation DC generator⁷.

In the schematic diagram, for simplicity of presentation, security system of table and system with mobile stop buttons are omitted.

On laboratory samples of cardan shafts, shafts were tested at a speed of 540 min^{-1} , which worked until they reached the total cycle number of 10^7 , which corresponds to the test of 300 work hours.

On this laboratory test table, were measured diagnostic sizes of already used double cardan shafts in the state before failure, but also samples from the laboratory. For the purpose of the test, variable load mode was used for a predetermined cycle of 50 work hours. Regimes that have been listed are load regimes which are quite frequent in practice. It is the necessary force which is required for driving agricultural implements (2, 3 and 4 kW), respectively 36, 55 and 75 Nm.

Identical laboratory tables for testing the reliability of mechanical transmissions are used in tests mentioned in Refs 9 and 10.

On laboratory-test table, electric brake for load simulation was designed and manufactured specifically for this research, model 'EK', type 6/28 (Ref. 11). On the system for load control on the electric brake EC 6/28 load at the output of the laboratory table could manually be assigned, through the value of power.

Thus, on the basis of written values (current I and voltage U) on the digital display, were calculated power P unit 1 (by equation (1)), respectively, the value of torque M through the measured power P and rev number revolutions n , equation (2), (Ref. 12):

$$P = UI \text{ (kW)}. \quad (1)$$

$$M = \frac{P9550}{n} \text{ (Nm)}. \quad (2)$$

RESULTS AND DISCUSSION

In Fig. 5 is shown the total average reliability of the observed diagnostic parameters, temperature and acceleration of axial vibration of the bearing sets on the first joints in both laboratory and exploitation conditions. Figure 5 shows the total average reliability of the observed diagnostic parameters, temperature and acceleration of axial vibration of the bearing sets on the first joints, in both laboratory and exploitation conditions. From Fig. 5 it can be concluded that the bearing sets of first joints in laboratory conditions, reached reliability of 10% in approximately 993 h, while those in the operating conditions, to achieve that percentage needed approximately 380 h.

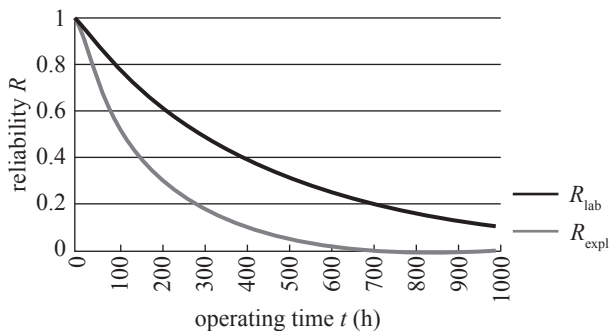

Fig. 5. Overall reliability of bearing assemblies of the first joints in laboratory and exploitation conditions

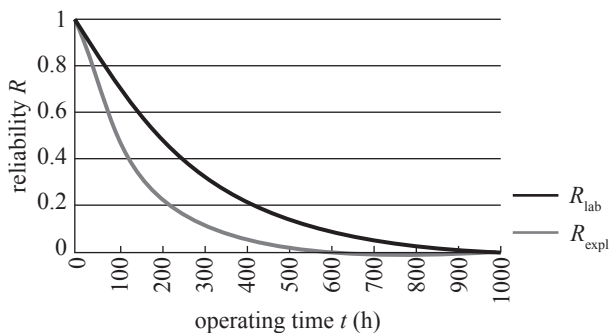

Fig. 6. Overall reliability of bearing assemblies of the second joints in laboratory and exploitation conditions

In Fig. 6 is shown the overall average reliability for the observed diagnostic parameters, temperature and axial acceleration of vibration, at the bearing sets of second joints in the laboratory and operating conditions. From Fig. 6 it can be concluded that the bearing sets of second joints in laboratory conditions, reached reliability of 10% in approximately 661 h, while those in operating conditions, to achieve that percentage needed approximately 321 h.

The final test of the overall reliability of double agricultural shafts, based on the average reliability of the observed diagnostic parameters of the first and second joints in the laboratory and exploitation conditions is shown in Figs 7 and 8. In Fig. 7 it can be seen that the average predicted reliability of cardan shafts in laboratory conditions was approximately 378 h of work, reliability of only second joints was approximately 611 h, while the reliability of the first joints was much higher. In Fig. 8 it can be seen that the average predicted reliability of cardan shaft in operating conditions was approximately 174 h of work, reliability of only other joints was approximately 321 h, while the reliability of the first joint was approximately 380 h.

Results of diagnostic studies at reliability testing of shafts on a laboratory table, at 20° rotation angle of the shaft, pointed to a very complex work conditions. The reasons why the test results of service life of double agricultural shafts in operating conditions, is different from the results obtained in the laboratory

Fig. 7. Average reliability of joints (shaft) in laboratory test

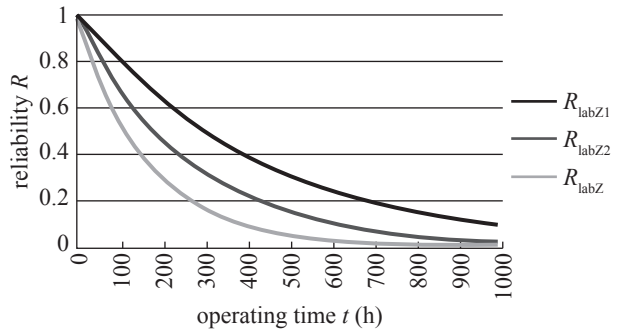
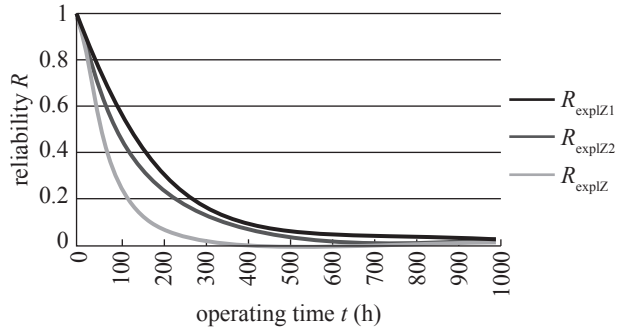

Fig. 8. Average reliability of joints (shaft) in exploitation conditions



conditions and why the level of exploitation of agricultural cardan shafts is much more complex, can be found in the following statements:

- Insufficient level of technical maintenance (primarily in the performance of lubrication process to be performed according to the recommendations of the manufacturer of cardan shafts, which were same for all shafts and it should be performed every 8 h of work).

- Unprotected (undefended) shafts from atmospheric influences both at the time the work and the time when the shaft is not used.

- Inability of constant maintenance of parallel angles to the input and output shaft due to the very complex conditions (terrain configuration, turning machines, etc.) prevailing in agricultural production.

- Sudden shock every time when you turn on the cardan shaft.

- Change of working angles during the cardan shaft work under load.

- Transfer of vibrations from the working machine and auxiliary machine to vibration in the bearing sets (assemblies) of cardan joint.

- Using shaft to work on several different implements: sometimes they are used on machines which torques exceed the permissible torque on the driveshaft transmissions.

- Failure to comply with instructions, which says that the drive shaft always rotate in the same direction.

- Inadequate use.

Key results of the research within mentioned reliability test of the double cardan shafts are:

- Second universal joint on a double cardan shaft is part of the technical system which fails first.

- Very low reliability and service time of agricultural shafts in operation, are consequences of inadequate technical maintenance and usage, as well as complex conditions that prevail in agricultural production.

- Almost identical diagnostic parameters on monitoring of bearing sets (assemblies) of cardan joints showed values of axial vibration, especially acceleration and temperature.

- The use of shafts is not recommendable in operation angle bigger than 20° , because at specified angles of rotation and at loads bigger than 75 N m, in terms of strictly parallel shaft in Z version, the level of axial vibration (acceleration) enters the zone of undesirable.

- With rotation angle of double cardan shafts of 20° even if it is used at minimum load of 36 N m, there was noticeable grease pouring from bearing assemblies on both joints, which must have been the result of high levels of vibration.

- At unidirectional variable load of 36.15, 55.25 and 74.86 N m, double cardan shafts in laboratory conditions at tests withstand without any visible damage to 304 h of work, while those in the exploitation conditions at tests lasted an average of 139 h of work.

- Predicted reliability in dual agricultural cardan shafts in exploiting (in state before reliability failure of 10%) could be increased by approximately 2.17 times and amounted to approximately 378 h (Figs 7 and 8).

- Being the most important reasons for deviation in the life of exploitation in relation to laboratory testing can be enumerated: inadequately technical maintenance, complex configuration of the terrain and conditions that govern of exploitation of the agricultural production, the possibility of short-term not the parallel between the input and output shafts and the like.

- As a consequence of the nonlinear contact between pin and the backwaters or of the cross, a cup in each branch of the cross was visible damage to in mind of thin surfaces of the upper part of the sleeves under the greatest an angle of $\sim 120^\circ$, respectively for a cup of 100° .

- A somewhat larger angle of damage has been discernible on the surface of the cross backwaters of other cardan joints in relation to the first.

- Represented mathematical models based on the analysis of diagnostic sizes were used in the analysis reliability of the double agricultural cardan shafts, are valid and represent an innovation in defining the reliability of these types of mechanical power transmission.

- Represented mathematical models based on the analysis of diagnostic parameters can be applied to other mechanical power transmissions.

The hypotheses under the supposition that the reliability of double agricultural cardan shafts in exploitation, with corner of rotation joints of shaft of 20° , reliability significantly lower than those in laboratory conditions testing, have been confirmed.

CONCLUSIONS

Reliability analysis of the double agricultural cardan shafts that are used in exploitation between the tractor and the implement machines point to the fact that their lifetime can be predicted. Exploitation of reliability examination cardan shafts pointed to the significantly smaller lifetime of bearing assemblies on the driveshaft the joints in relation to the laboratory examination conducted. As the primary reasons that affect it, are the following: the inadequate maintenance of, complex configuration of the terrain, the conditions that exist in the agricultural production, inappropriate use, etc.

Test results indicated that one should not use the agricultural double cardan shafts in angles rotation of the joints of more than 20° . Under specified rotation angles of joints and with very small workloads in the used in examination of reliability cardan shafts are noticed occurrence of very high values of diagnostic parameters and lacking of lubricant from the bearing assemblies during operation. Condition diagnostics of roller bearing sets agricultural machinery on cardan shafts, for the given conditions of use, pointed to all deficiencies of this mechanism in process of exploitation, on proposed measures of continuing exploitation (through the lifetime of the roller bearings) in order to increase the reliability of cardan shafts.

REFERENCES

1. I. FISCHER, J. K. de WAAL: Experimental Study of Cardan Joint Dynamics, *ASME J Mech Des*, American Society of Mechanical Engineers, **117** (4), 526 (1995).
2. M. N. EROHIN, A. G. PASTUHOV: Reliability of Cardan Shaft in Transmissions of Agricultural Engineering in Exploitation. Belgorod State Agricultural Academy, Belgorod, 2008 (in Russian).
3. A. ASONJA, D. MIKIC, B. STOJANOVIC, R. GLIGORIC, L. SAVIN, M. TOMIC: Examination of Motor-Oils in Exploitation at Agricultural Tractors in Process of Basic Treatment of Plot. *J Balk Tribol Assoc*, **19** (2), 314 (2013).
4. A. G. PASTUHOV: Improving the Reliability of Cardan Shaft in Transmissions of Agricultural Engineering. Ph.D. Thesis, Belgorod State Agricultural Academy – Moscow State Agro-engineering University named after V. P. Goryachkin (MSAU), Moscow, 2008 (in Russian).
5. Iowa Face Program: Tanker Truck Driver Killed by Unshielded PTO Shaft, Case No 2IA24, The University of Iowa, 2002.

6. M. CECCHINI, D. MONARCA, P. BIONDI, A. COLANTONI, G. MENGHINI, G. BRENCI-AGLIA: Safety of Tractor PTO Drive Shafts: Survey on Maintenance on a Sample of Farms in Central Italy, Efficient and Safe Production Processes in Sustainable Agriculture and Forestry. In: XXXIV CIOSTA CIGR V Conference, 2011.
7. A. ASONJA, Z. ADAMOVIC, R. GLIGORIC, D. MIKIC: The Development of a Laboratory Stand for Examination the Reliability of Agriculture Cardan Shafts. *Tech Diagnost*, **11** (3), 27 (2012).
8. A. ASONJA, Z. ADAMOVIC, N. JEVTIC: Analysis of Reliability of Cardan Shafts Based on Condition Diagnostics of Bearing Assembly in Cardan Joints. *J Metall Int*, **18** (4), 216 (2013).
9. B. STOJANOVIC, M. BABIC, N. MARJANOVIC. L. IVANOVIC, A. ILIC: Tribomechanical Systems in Mechanical Power Transmitters. *J Balk Tribol Assoc*, **18** (4), 497 (2012).
10. B. STOJANOVIC, M. BABIC, S. MITROVIC, N. MARJANOVIC, A. VENCL, N. MILORADOVIC, M. PANTIC: Tribological Characteristics of Aluminium Hybrid Composites Reinforced with Silicon Carbide and Graphite. *J Balk Tribol Assoc*, **19** (1), 83 (2013).
11. A. ASONJA, Z. ADAMOVIC, R. GLIGORIC, A. PASTUHOV, D. MIKIC: The Development of the Electric Brake Model on Stand for Testing the Reliability of Agricultural Cardan Shafts. In: II International Conference – Industrial Engineering and Environmental Protection (IEEP 2012), October, Zrenjanin, Serbia, 2012, 147–151.
12. B. ILIC, Z. ADAMOVIC, N. JEVTIC: Application Method of Artificial Intelligence in Reaching Conclusions on the Situation Diagnostic Machine in Process Industry. *Tech Diagnost*, (Belgrade), **11** (3), 33 (2012).

Received 12 December 2013

Revised 21 January 2014