

## TRIBOMECHANICAL SYSTEMS IN DESIGN

B. STOJANOVIC\*, L. IVANOVIC

*Faculty of Engineering, University of Kragujevac, 6 Sestre Janjic Street,  
34 000 Kragujevac, Serbia*

*E-mail: blaza@kg.ac.rs*

### ABSTRACT

The usual tribomechanical systems that are used in the process of development design are presented in this paper. Complex processes of friction and wear at contact surfaces are done within those tribomechanical systems.

The basic tribological characteristics of tribomechanical systems are friction and wear that are the main causes of system structure alteration, energy and material losses. As natural processes, friction and wear depend on large number of factors such as: system structure, exploitative conditions (speed and load), mechanical and chemical properties of material, lubrication characteristics, environment aggressiveness, temperature, topography of surfaces in contacts, mechanical processing (pre- and post-processing) an so on.

The number of influential factors and complexity of their interactions in which variation of one parameter caused chain alterations of different parameters complicate the quantification of theirs influences. Those are the reasons for present insufficiency of systematic information about tribological characteristics of tribomechanical systems.

*Keywords:* tribomechanical systems, engineering design, friction, wear.

### AIMS AND BACKGROUND

The developments in technical sciences were linked with production of technical systems, their evaluations, modifications and optimisations, so as production processes and reparations. In the early stage of mechanical engineering the technical sciences such as theory of metal cutting, metal science, machining tools and shipbuilding technology are developed. Construction and engineering design

---

\* For correspondence.

methodology were developed later. The scientific bases of technical systems developments are established in production processes at companies and represent the sources of information for the different specialists after taking of serial production processes. The typical examples of tight correlation between production and science are the development and production of electronic computer systems, also the development of cosmic sciences and cosmic technology.

Using of tribology knowledge in the project development procedures, construction engineering and design procedures was minimum in relation to using of the other technical knowledge. Tribological information was not required in using and exploitation. The constructors focused on improvement of reliability during exploitation and avoiding the failures while the wear was considered as additional requirement. The capacity calculations of static and dynamic stability and rigidity were considered for long period of time as relevant for reliable and efficient functioning of machines in exploitation. For specific exploitative conditions of machines, those calculations can be relative easy. Further technical and technological developments implicate the increase of power, speed and load to improve the productivity. The machine systems functioned within strict exploitative limits. At that time, constructors started to consider the causes of failures and very often to cut the nominal resources of exploitation. The detailed analysis started to implicate that common causes of failures were extensive wear and tribological processes at vital elements of machines and its parts. This was obvious especially at petroleum and liquefied petroleum gas industry, mining and agricultural industry<sup>1-3</sup>.

The problems related to improvement of the wear resistance of machine elements suddenly become very important, but they are still solved by load capacity methods. In specific cases, the problem of improvement of the wear resistance are solved by using the steel grades with higher hardness. The steels are considered as the analogies for wear resistance. Lather, the importance was given to lubricants so the problems related to wear minimising were solved by the adequate choosing of lubricants<sup>4</sup>.

Long and difficult implementing of tribology knowledge in the mechanical engineering construction sciences such as machine elements and machining tools science can be explained in different ways and from different aspects. The nature of the tribology basics is analysed, as a science discipline, by: mechanical engineers, chemists, technologists, material engineers, physicists and other specialists, all from own specific aspect. This wideness of possible aspects of interest is also very important characteristic of tribology due to its interdisciplinary nature. At the same time, due to presented facts this science discipline was not used for very long time because data and information obtained by fundamental researched did not satisfy practical needs in projects development and construction<sup>5-7</sup>.

## TRIBOMECHANICAL SYSTEMS

From the aspect of tribology adequate constructions, the basic functions executors that act on the principle of friction contacts at the elements with relative motion are very important. Those basic functions executors are known in the tribological theories as tribomechanical systems (TMS). At the zones of friction contacts the complex, non stationary physical, chemical and mechanical processes are present and they are followed by friction and wear of contact surfaces. The problems related to friction and wear present the problems of contact mechanics acting, chemical processes in the friction zones and physical problems of dissipative processes at surface levers of contact surfaces.

Tribomechanical systems, as dynamic executors of elementary functions are of special interest at conceptual and constructional stage of project development because those tribomechanical systems determined the reliability of whole machine systems in 80% of failure causes. Furthermore, the qualities of constructions are often identified by the qualities of its tribomechanical systems.

Many researches showed that the periods of functional ageing of machine systems have been significantly longer than periods of allowed wear of system elements<sup>8-10</sup>. Physical wear of elements (1.5÷2 years) run faster than functional ageing (5÷10 years) of machine systems. The basic objective is equivalence between functional aging and allowable wearing. The basic objective of tribology is to minimize the difference in lasting of those two time periods as soon as possible. This is the fact why choosing and construction of tribomechanical systems are of high importance in conceptual and final construction forming.

## TRIBOMECHANICAL SYSTEM AS 'BLACK BOX'

The theory of system defines the system as entity of elements arranged structurally and functionally with certain interactions. From this aspect, tribomechanical systems are defined as entities that are functionally related to interactions of contact surfaces which are in relate motion. The term 'tribomechanical system' referees to presence of tribological processes at the elements of the system, so as to developments of mechanical interactions.

In technical, especially machine systems, the function of the system is presented by transformation of input values  $\{X\}$  to output values  $\{Y\}$ . In abstract and very simplified description, the functions of different tribomechanical systems are related to transformation of input values, for example, motion, mechanical energy and material in positive and useful output values. The functional cause-consequential relationships between input and output are followed by losses in mechanical energy and material that are identified as friction and wear losses.

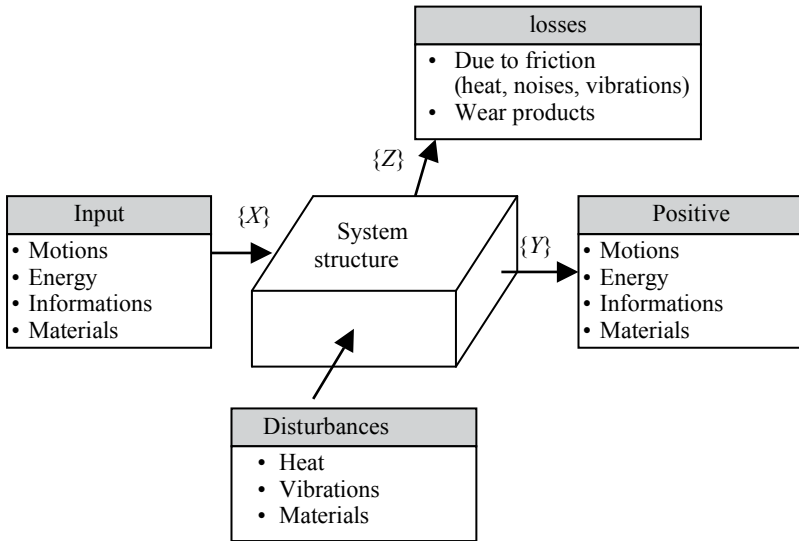

**Fig. 1.** Tribomechanical system as ‘black box’

By the basic cybernetic and systematic method that can be used for analyses of unknown and very complex dynamic systems, the tribomechanical system can be considered as ‘black box’ with input and output<sup>1,11</sup> (Fig. 1).

The function as main characteristic of tribomechanical systems can be presented as relation between input and output values. It is impossible to obtain every input to be beneficial, nor every output to be useful. Some inputs can be considered as disturbances that induce losses at the outputs. Those losses are not often of the same nature as input value or useful output.

From the aspect of the adequate realisation of the elementary functions, the losses in tribomechanical systems, especially losses for friction and wear are of the special interest for the analysis presented in this paper. The friction as process that opposes to motion of the system elements determined the mechanical degree of efficiency that is dominant factor for quantify the system ability to preserve the energy in transmission. The wear as the process of material dissipation from contact surfaces induced the alteration of the technical properties and alteration of the function of system.

The acting of disturbances values induced the oscillatory movement that produced vibration and noise. The vibrations can be identified as periodic movement of elements of tribomechanical systems with higher or lower frequencies or as unsteady elastic deformations of elements. The energy of these oscillations is transmitted to environment while the part of this energy with appropriate frequency and amplitude is transmitted to acoustic environment so producing noise with different levels of intensity.

The fact that mechanical energy during friction can not be destroyed and just turns to heat implicates the relation between thermal processes and tribology, especial if temperature alteration affects friction and wear. From this aspect, heat influence to friction, wear and vibration process are defined.

The motion is the dominant input factor of every tribomechanical system. The motion is followed by transmission of energy, material or information. In realisation of defined elementary functions, the tribomechanical systems can alter the motion speed or stop it. The tribomechanical systems can limit motions, and also, those systems can reduce the number of degrees of freedom. In other cases, material in motion, also, changes its structure and form. Tribomechanical system is also used for generation and transformation of information. But, the fact is that in present the usages of devices for generation of information with mechanical elements are decreasing (replacement of mechanical clocks with electronic one, for example).

## CLASSIFICATION OF TRIBOMECHANICAL SYSTEMS

The technical processing of elements in contact and motion enclosed very wide range of application: from cosmic and aeronautic to biomechanical devices. From that point of view, large number of tribomechanical systems that is used in the construction process and the process of the realisation of those constructions are normal consequences. The number of tribomechanical systems used in one machine tool, car or industrial system is surprisingly high. In order to simplify the identification and use of tribomechanical systems as the executors of basic functions in conceptual stage of construction development and in construction forming, the classification was done. In relation to function that performs and in relation to the input values that transforms, following classification of tribomechanical systems can be done<sup>1,5,11,12</sup> (Fig.2):

- (a) transmission of motion,
- (b) transmission of power,
- (c) transmission of information,
- (d) transfer and processing of material.

It is obvious that the presented classification is general and that it is useful to subdivide it to more details. For example, the tribomechanical systems that transmit motion can be further classified in one that transmits motion in transversal direction (bearings), one that transmits motion in longitudinal direction (couplings), linear direction (guides) or one that stops the motion (brakes). Information can be produced and replicated. Material can be transferred, formed, processed, but also, it can be cut<sup>13-15</sup>.

By detailed analysis the tribomechanical systems can be classified in details. The bearings can be of rolling or sliding type, but also, radial and axial. Power transmitter can transmit power by form, but also by friction.

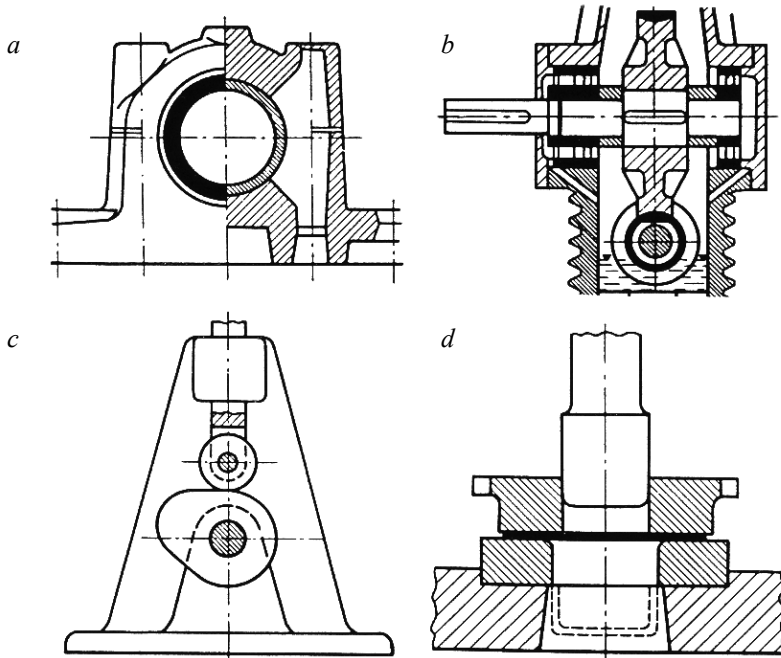

**Fig. 2.** Basic types of tribomechanical systems

*a* – motion transmission; *b* – power transmission; *c* – information transmission; *d* – material processing

On the basis of the presented classification, Table 1 is formed by the commonly used tribomechanical systems that are used at constructions. The classification presented in Table 1 does not pretend to be final classification and it points out to wide use of tribology in mechanical systems.

The classified tribomechanical systems are basic with simple hierarchy because they are used as executors of elementary functions. Those systems are grouped in the higher level systems performed partial and main functions and formed conception of tools, machines, transport devices and so on.

The classified tribomechanical systems are not equal in structure and in hierarchy affiliation. The following rules are present:

1. Systems belong to different classes of complexity.
2. All the conditions (logical and empirical) of the low level system also exist in every higher level system that is formed in its turn of the low level system.
3. With rising of complexity level of the system, the number of unknown elements and undefined interactions that determine the function of the exact system, also, rises.

**Table 1.** Commonly used tribomechanical systems in design

Main input value	Main output value	The basic function of system	Tribomechanical systems (TMS)
1	2	3	4
Motion + Energy	Motion	transmission of rotation in transverse direction	<ul style="list-style-type: none"> <li>• slide bearings</li> <li>• ball and cylindrical roller bearings</li> <li>• needle roller bearing</li> <li>• tapered roller bearing</li> <li>• gyroscope bearings</li> <li>• leading bearings</li> <li>• ball-thread mechanisms</li> </ul>
		transmission of rotation in longitudinal direction	<ul style="list-style-type: none"> <li>• flanges</li> <li>• toothed joints</li> <li>• groove joints</li> <li>• polygonal joints</li> <li>• conical joints</li> <li>• collet joints</li> <li>• line joints</li> <li>• flexible joints</li> </ul>
		transmission of linear motion motion braking	<ul style="list-style-type: none"> <li>• slide guides</li> <li>• rolling guides</li> <li>• pad brakes</li> <li>• tape brakes</li> <li>• drum brakes</li> <li>• friction absorber</li> <li>• lock joints</li> </ul>
	Power	power transmission	<ul style="list-style-type: none"> <li>• spur gear transmitter</li> <li>• cylindrical gear transmitter</li> <li>• conical gear transmitter</li> <li>• hypoid gear transmitter</li> <li>• planetary gear transmitter</li> <li>• worm transmitter</li> <li>• chain transmitter</li> <li>• belt transmitter</li> <li>• flat belt transmitter</li> <li>• friction transmitter</li> <li>• planetary friction transmitter</li> <li>• timing belt transmitter</li> <li>• thread transmitter</li> <li>• Cardan transmitters</li> <li>• variators</li> <li>• flexible shafts</li> <li>• rope drive</li> <li>• jack lift with wind spindle</li> <li>• hydraulic transmitters</li> </ul>

to be continued

Continuation of Table 1

1	2	3	4
Motion + Energy	Information	production of information	<ul style="list-style-type: none"> <li>• clock mechanisms</li> <li>• cam mechanisms</li> <li>• curvature mechanisms</li> <li>• eccentric mechanisms</li> <li>• the Maltese cross mechanisms</li> <li>• assemblies of the printing machines</li> <li>• assemblies of the computer machines</li> <li>• electro-contact mechanisms</li> </ul>
		reproduction of information	<ul style="list-style-type: none"> <li>• computer magnetic head</li> <li>• device with contact rings</li> <li>• sound players</li> <li>• video players</li> </ul>
Motion + Energy	Material	material movement	<ul style="list-style-type: none"> <li>• wheel -rail</li> <li>• tire-road</li> <li>• pipeline</li> <li>• assemblies of conveyer</li> <li>• bucket of bucket wheel excavator</li> </ul>
		regulation of material flow	<ul style="list-style-type: none"> <li>• fittings</li> <li>• valves</li> <li>• filters</li> <li>• piston devices</li> </ul>
		material forming	tool-material for: <ul style="list-style-type: none"> <li>• wire drawing</li> <li>• deep drawing</li> <li>• punching</li> <li>• slitting</li> <li>• bending</li> <li>• extrusion</li> <li>• forging</li> <li>• rolling</li> <li>• casting</li> <li>• die casting</li> <li>• parts of yarn machines</li> <li>• parts of weaving machines</li> </ul>
		material cutting	different elements for: <ul style="list-style-type: none"> <li>• mineral excavation</li> <li>• well drilling</li> <li>• surface mining</li> <li>• crushing</li> <li>• digging</li> </ul>
		material processing	tool-material for: <ul style="list-style-type: none"> <li>• cutting</li> <li>• separation processing</li> <li>• cutting</li> <li>• scraping</li> <li>• milling</li> <li>• planing</li> <li>• drilling</li> <li>• inside scraping</li> <li>• grinding</li> <li>• lapping</li> <li>• polishing</li> <li>• honing</li> <li>• sanding</li> <li>• painting</li> </ul>



Gear transmitters are basic tribomechanical system due to its structure that consisted of 2 separated gears and lubricant that separates those gears. Chain transmitter is more complex due to its structure that consisted of many basic tribomechanical systems: pin-bush-lubricant; bush-roller-lubricant; roller-sprocket teeth-lubricant. The basic TMS in metal cutting is cutting tool–material–coolant and lubricant, etc.

## CONCLUSIONS

From the aspect of tribological processes analysis and forming of systematic information, the basic tribomechanical systems are of special interest. The tribological processes occur at basic tribological systems that are composed of 2 elements in contact in the presence of lubricant as a third element. Environment as a fourth element completed the structure of the basic tribomechanical system.

The analysis of the basic tribomechanical systems is of very significant importance in the conceptual stage of the construction development, when the elements and assemblies are defined and formed. Adequate construction is the construction from the aspect of tribology and it requires analysis, forming and dimensioning of every basic tribomechanical system that is included in structures of complex tribomechanical systems. This fact is of primary importance at the original tribomechanical system for which the quantity of relevant information is insufficiently small.

## ACKNOWLEDGEMENT

This paper presents the research results obtained within the framework of a project TR–35021, financially supported by the Ministry of Education and Science of the Republic of Serbia.

## REFERENCES

1. S. TANASIJEVIC: Tribologically Correct Design. Faculty of Mechanical Engineering, Kragujevac, 2004 (in Serbian).
2. Gw. STACHOWIAK, AW. BATCHELOR: Engineering Tribology. Elsevier Butterworth-Heinemann, Oxford, 2006.
3. Ta. STOLARSKI: Tribology in Machine Design. Elsevier Butterworth-Heinemann, Oxford, 1999.
4. A. RAC: Lubricants and Machine Lubrications. Faculty of Mechanical Engineering, Belgrade, 2007 (in Serbian).
5. B. STOJANOVIC, M. BABIC, N. MARJANOVIC, L. IVANOVIC, A. ILIC: Tribomechanical Systems in Mechanical Power Transmitters. *J Balk Tribol Assoc*, **18** (4), 497 (2012).

6. S. TANASIJEVIC, B. STOJANOVIC, N. MILORADOVIC: Eco-tribological Correct Design: New Demands of Contemporary Design. J Balk Tribol Assoc, **16** (4), 608 (2010).
7. B. STOJANOVIC, S. TANASIJEVIC, N. MILORADOVIC: Tribomechanical Systems in Timing Belt Drives. J Balk Tribol Assoc, **15** (4), 465 (2009).
8. N. MARJANOVIC, B. IVKOVIC, M. BLAGOJEVIC, B. STOJANOVIC: Experimental Determination of Friction Coefficient at Gear Drives. J Balk Tribol Assoc, **16** (4), 517 (2010).
9. B. STOJANOVIC, N. MILORADOVIC, M. BLAGOJEVIC: Analysis of Tribological Processes at Timing Belt's Tooth Flank. Tribol in Industry, **31** (3&4), 53 (2009).
10. B. STOJANOVIC, L. IVANOVIC, M. BLAGOJEVIC: Friction and Wear in Timing Belt Drives. Tribol in Industry, **32** (4), 33(2010).
11. H. CZICHOS: Tribology-A Systems Approach to the Science and Technology of Friction. Lubrication and Wear. Elsevier, Amsterdam, 1978.
12. B. STOJANOVIC, S. TANASIJEVIC, N. MARJANOVIC, L. IVANOVIC, M. BLAGOJEVIC: Wear as the Criterion of Mechanical Transmitters Working Life. J Balk Tribol Assoc, **17** (2), 215 (2011).
13. J. GLISOVIC, R. RADONJIC, D. MILORADOVIC: Experimental Method for Analyzing Friction Phenomenon Related to Drum Brake Squeal. Tribol in Industry, **32** (4), 28 (2010).
14. M. BABIC, S. MITROVIC, I. BOBIC, F. ZIVIC: Wear Behavior of Composites Based on ZA-27 Alloy Reinforced by  $Al_2O_3$  Particles Under Dry Sliding Condition. Tribol Let, **38** (3), 337 (2010).
15. L. IVANOVIC, D. JOSIFOVIC, A. ILIC, B. STOJANOVIC: Tribological Aspect of the Kinematical Analysis at Trochoidal Gearing in Contact. J Balk Tribol Assoc, **17** (1), 37 (2011).

*Received 29 September 2013*

*Revised 20 December 2013*