

# THE INFLUENCE OF VARIATION IN POSITION OF OUTPUT SHAFT TO LOAD ON THE CARDAN JOINT CROSS SHAFT

*Boris Rakić<sup>1</sup>, Master student, Lozica Ivanović, Associate professor, Danica Josifović, Full professor, Blaža Stojanović, Assistant, Andreja Ilić, PhD Student*

UDC: 621.825

## INTRODUCTION

Fast development of Cardan mechanisms and their' even wider usage are implicated by development of agricultural and transport mechanical engineering. The area of Cardan mechanisms usage, its exploitation properties, reliability and function ability in different exploitation conditions are determined by its constructional characteristics. Cardan mechanisms are used in many area of mechanical engineering as mechanical power transmitters, and its general classification is done on the constructional possibilities of torque transmitting. In present mechanical construction, the Cardan mechanisms with cross shaft is commonly used [11]. At tractors and other working machines, the Cardan shaft is used for transmission of power from the engine to the devices that are not rigidly connected with the engine (additional devices, tractor trailer, ...) for connecting shaft. Cardan transmitters are widely used at agricultural equipment due to possibility of continual changing of relative position of shafts in transmitter mechanism in exploitation caused by changing of terrain and characteristics of technological process. The present researches of Cardan shafts are focused on improvement of its reliability in exploitation at agricultural equipment that works in even harder conditions.

The causes of failures and design of power transmitters with Cardan shafts are analyzed by many researches. Hummel and Chassapis [2] researched on the design of the universal joints. They give some suggestions on the configuration design and optimization of universal joints with manufacturing tolerances [3]. Bayrakceken et al. [1] performed the fracture analysis of a universal joint yoke and a drive shaft of an automobile power transmission system. Spectroscopic analyses, metallographic analyses and hardness measurements are carried out for each part. For the determination of stress conditions at the failed section, stress analyses are also carried out by the finite element method (FEM). The reference [8] considered modification of design of Cardan shaft in order to avoid failures during exploitation period. The modifications of designs are analyzed by finite elements methods and the best modification of design with decrease of dimensions of input Cardan joint yoke is identified.

For the rational design, safety and reliability evaluations of machines' elements it is necessary to determine the stress levels and its distributions in the critical zones. The stress level and its distributions depend on load characteristics so as on the shape of the machines' elements. At the zones with variation in shape and dimensions of cross section the stresses are irregularly distributed and the maximal stresses are far greater than nominal stresses. Besides that, the multiple stress concentrations as the consequence of multiple stresses concentrators influence are induced [6]. For the aim of reducing the stress concentration the design and technological procedures are done. By the increase of fillets at critical zones, the

---

<sup>1</sup> Boris Rakić, Master student, Faculty of Engineering, Sestre Janjić 6, 34000 Kragujevac, Serbia, e-mail: [borismfkg@gmail.com](mailto:borismfkg@gmail.com)

stress concentrations can be significantly reduced. But, the possibilities of this procedure are limited due to interferes with axial support of bearings. In the paper [5] the procedure of identification of optimal combination of shape and dimensions of shape transition zones from the aspects of maximal stresses reductions is shown.

By the analysis of information and data obtained in many researches related to this area referred the fact that exploitation reliability of Cardan shaft in working machines are directly determined primary by reliability of needle bearing and cross shafts. Roller bearings and cross shafts work in very hard conditions because in exploitation high impacts loads are provoked. The main causes of high impact loads are inhomogeneity of ground and variation on operation angles due to agri-technical condition in which agriculture equipment is used. In those causes operation angle can overcome the defined limit. In the cause when Cardan shafts worked with high operating angles the increase of inertial forces are induced that act on roller bearings and Cardan shaft with external load. This processes lead to severe damages of roller bearings and cross shafts that have failure and breakage of Cardan shaft, as consequence. To the aim the better understanding of possibilities of improves the reliability of working machines the object of research that is presented in this paper, is the analysis of the influence of variation in position of output shaft to load on the Cardan joint cross shaft.

## 1. KINEMATIC OF CARDAN MECHANISMS

A universal joint is a positive, mechanical connection between rotating shafts, which are usually not parallel, but intersecting. They are used to transmit motion, power or both.

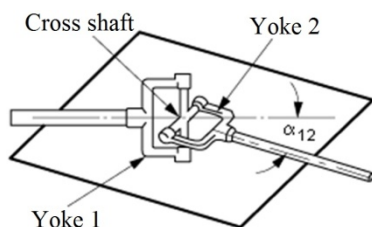

*Figure 1: Single Cardan joint [12]*

The simplest and most common type is called Cardan joint or Hooke joint. It is shown at Figure 1 and it consists of two yokes, one on each shaft, connected by a cross-shaped intermediate member called the cross shaft. The angle between the two shafts is called the operating angle and it is, in general, but not necessary, constant during operation. Good design practice requires low operation angles, often less than  $25^\circ$ , depending on the application. Independent of this guideline, mechanical interference in the construction of Cardan joints limits the operating angle to a maximum value that depends on its proportions.

The main property of the Cardan mechanisms is possibility of changing the rotation speed ratio. Amplitude of periodical variation of rotation speed ratio depends on value of the angle between input and output shafts [10], [11]. The relation between the rotation angles of input and output shafts is function of their' relative positions in the area.

Independently of types and constructional solutions of Cardan mechanisms the basic kinematic relations are equivalent. The Cardan mechanism with angle  $\alpha_{12}$  between

shafts is presented at Fig. 1. If the rotation angle of input shaft is  $\varphi_1$  then rotation angle of the output shaft is  $\varphi_2$ . The relation between those angles presents the basic kinematic principle that is given in the following form [11]:

$$\varphi_2 = \arctg\left(\frac{\operatorname{tg}\varphi_1}{\cos\alpha_{12}}\right). \tag{1}$$

The difference in value of angles  $\varphi_1$  and  $\varphi_2$  implicate the difference in rotational speeds of the corresponding shafts ( $\omega_1=d\varphi_1/dt$ ,  $\omega_2=d\varphi_2/dt$ ) and the value of that difference in rotational speeds can be obtained by differentiation of the equation (1). By applying certain trigonometrical transformation the relation for rotation speed ratio of Cardan mechanism can be obtained [11]:

$$i_{21} = \frac{\omega_2}{\omega_1} = \frac{\cos\alpha_{12}}{1 - \sin^2\alpha_{12}\cos^2\varphi_1}. \tag{2}$$

Diagram of relations between certain kinematic parameters at Cardan mechanism is presented at Fig. 2, Fig. 3 and Fig. 4.

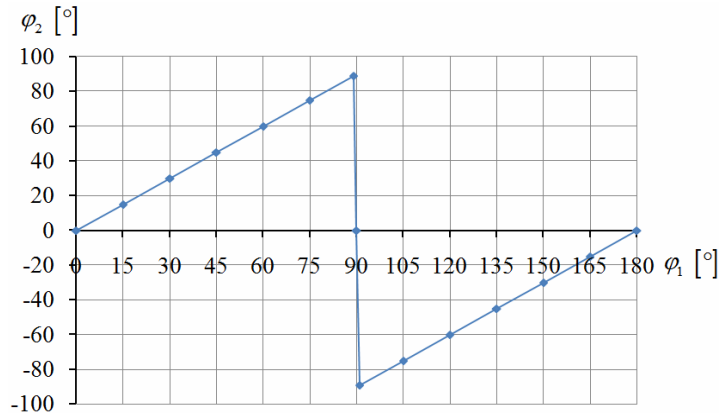

**Figure 2:** The relations between the rotation angles of shafts at Cardan joint

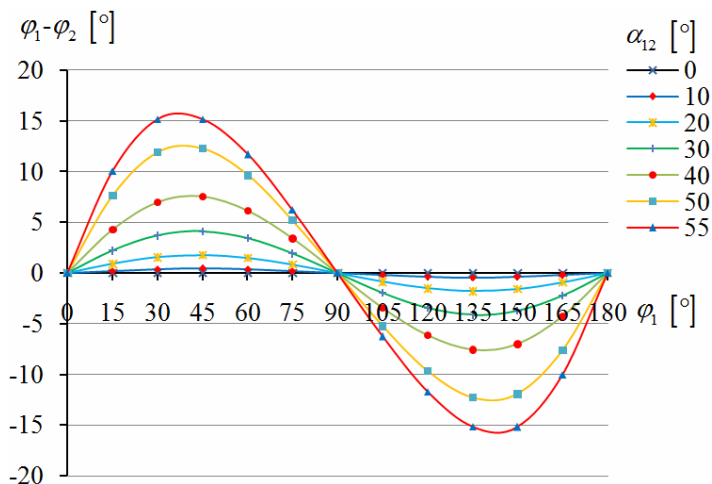

**Figure 3:** The difference of rotation angles of input and output shafts at Cardan joint

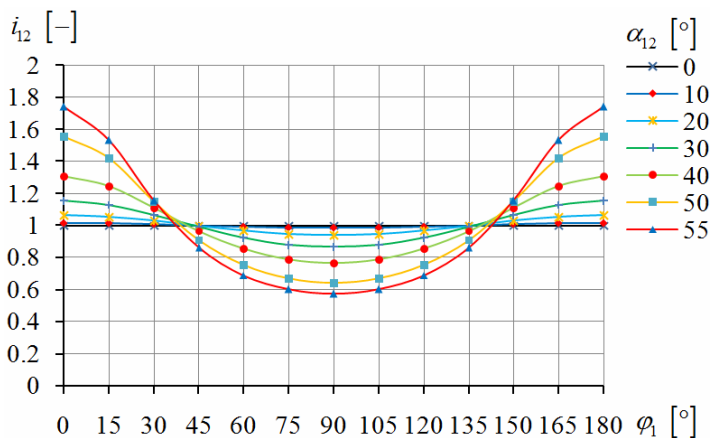

**Figure 4:** Ratio between the angular velocities  $i_{21} = \omega_2/\omega_1$

## 2. CALCULATION OF STRESSES ON CARDAN JOINT CROSS SHAFT AT DIFFERENT ROTATION ANGLES

The elements of Cardan joint are loaded by complex loads on flexion, torsion, shear and surface pressure. The different phenomena of failures in material can be induced in exploitation due to overload that could lead to damages and breakages of Cardan joint elements. The usual zones in which those failures occurred are zones at the basis of branches of the Cardan joint yoke. The initial cracks as causes of failures often started on the cross shaft in the zone of hole below the lubrication spot. Kinematic of power transmitters with Cardan joints is very specific from the aspect of variation in relative positions of input and output shafts that cause the variation of maximal stresses at branches and central zone of the cross shaft.

**2.1 Calculation of stresses by analytic method**

The research presented in the paper [5] implicate that maximal stresses at the basis of the branches of the cross shaft can be significantly reduced by modifications of shape and fillet at the zones of shape transitions. The conducted research implicate that optimal design solution of shape transition zone from the central part to the branches is one with bigger level of fillet and chamfer with angle less of 45° to the cylindrical part for the base of needle bearing. The calculation of stresses by analytic method is done for the design of cross shaft, presented at Fig. 5. The dimensions of considered model are limited by construction requirements. The basic properties of considered power transmitter with Cardan joint are: power  $P=25$  kW, number of rotation  $n=1500$  min<sup>-1</sup>, distance between top of branches and critical cross section  $h_1=21.5$  mm, the length of bearing zone  $h_2=17.5$  mm, distance between two top sides of opposite branches  $L=70$  mm, diameter of branches  $d=18$  mm, diameter of hole for supply of lubricant  $d_1=4$  mm, the angle between input and output Cardan joint yokes is  $\alpha_{12}=(0\div55^\circ)$ .

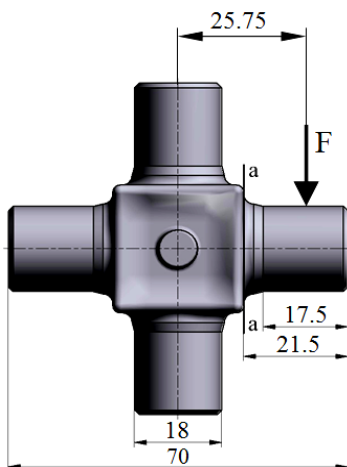

**Figure 5:** Dimensions and shape of cross shaft

The determined value of stress presents the maximal value of stress at critical cross section. This value is not determined for the real shape of cross shaft that enclose the presence of stress concentrators, so for determination of stresses at real model of cross shaft the numerical method must be used. From the aspect that cross shafts can be made of different steel grades, some data obtained in exploitation indicate that it is beneficial if bending stress do not exceed 150 MPa [11]. The torsion torque on input shaft  $T_{u1}$  is in equivalence with torsion torque  $T_{u2}$  on output shaft. For determination on value of the torque  $T_{u2}$  at current position of Cardan mechanism defined by rotation angle  $\varphi_1$ , the method of possible movements is used. According to this method the result of actions of all elementary actions of active forces that act on the system during any possible movement is equal to zero [11]. For the static equivalence, the following relation must be satisfied:

$$T_{u1}d\varphi_1 - T_{u2}d\varphi_2 = 0. \tag{3}$$

On the basis of the assume that support bearings are rigid, the possible movement of the shafts 1 and 2 are only rotation defined by elementary angles  $d\varphi_1$  and  $d\varphi_2$ . The relation between angles  $\varphi_1$  and  $\varphi_2$  is presented by equitation (1). By the transformation of the equitation (1) and using the equitation for static equivalence the torsion torque on output shaft can be determined in the following form:

$$T_{u2} = T_{u1} \frac{\cos^2 \varphi_1 \cos^2 \alpha_{12} + \sin^2 \varphi_1}{\cos \alpha_{12}}, \quad (4)$$

while maximal force on branch of the cross shaft can be determined as:

$$F = \frac{T_{u2\max}}{L - h_2}. \quad (5)$$

The stress due to flexion at the basis of the branches of the cross shafts (critical cross section a-a, presented at Fig. 5) can be determined by following relation:

$$\sigma_s = \frac{32 \cdot T_{u2\max} \cdot \left( h_1 - \frac{h_2}{2} \right)}{(L - h_2) \cdot \pi \cdot (d^3 - d_1^3)}, \quad (6)$$

while shear stress can be determined by relation:

$$\tau = \frac{4 \cdot F}{\pi \cdot (d^2 - d_1^2)}, \quad (7)$$

so result stress is equivalent to:

$$\sigma = \sqrt{\sigma_s^2 + 3 \cdot \tau^2}. \quad (8)$$

Values of the result loads at extreme rotation positions ( $\varphi_1=0^\circ$  and  $\varphi_1=90^\circ$ ) and values of stresses obtained by analytic method using relations given in this paper are presented at Tab. 1. The values of the stresses that are obtained with neglecting the stresses concentrations are not relevant, so numeric calculations of stresses must be done.

**Table 1:** Load at cross shaft as function of variation of operation angle  $\alpha_{12}$  in extreme positions

$\alpha_{12}$ [°]	$T_{\alpha_{12}}$ [Nmm]		$F$ [N]		$\sigma_z$ [MPa]		$\tau$ [MPa]		$\sigma$ [MPa]	
	$\varphi_1 = 0^\circ$	$\varphi_1 = 90^\circ$	$\varphi_1 = 0^\circ$	$\varphi_1 = 90^\circ$	$\varphi_1 = 0^\circ$	$\varphi_1 = 90^\circ$	$\varphi_1 = 0^\circ$	$\varphi_1 = 90^\circ$	$\varphi_1 = 0^\circ$	$\varphi_1 = 90^\circ$
0	159166.67	159166.67	3031.75	3031.75	68.26	68.26	12.53	12.53	71.63	71.63
10	156748.57	161622.07	2985.69	3078.52	67.22	69.31	12.34	12.73	70.54	72.74
20	149567.74	169381.63	2848.91	3226.32	64.14	72.64	11.78	13.34	67.31	76.23
30	137842.38	183789.84	2625.57	3500.76	59.12	78.82	10.85	14.47	62.03	82.71
40	121928.74	207777.33	2322.45	3957.66	52.29	89.11	9.60	16.36	54.87	93.51
50	102310.36	247619.38	1948.77	4716.56	43.88	106.20	8.06	19.50	46.04	111.44
55	91294.25	277498.62	1738.94	5285.69	39.15	119.01	7.19	21.85	41.08	124.88

**2.2 Calculation of stresses by numeric method**

The design and process of project development of power transmitter with Cardan joint must be done with great care due to the set of constructional requirements that must be fulfilled by design solution. The results obtained by analytic calculations cannot take as relevant in all cases because those calculations are done on simplified model. The method of numeric calculation by finite element analysis is the one of the methods that provides calculations on the mathematical models with real geometry.

The analysis by FEM method is much more precise in relation to analytic method. The finite element method provides possibility of fast repeated calculations after modifications of some design details of considered element. In this paper the simulation of load at cross shaft done using the software package *Autodesk Inventor Professional 2011* is presented. The analysis by finite element method require following procedure [7]: creation of geometric model, definition of material, discretization by finite elements, definition of support location and load limitations, the specification of location and characteristic of load, numeric calculation and interpretation of results.

The basic considered model for analysis by FEM method in this paper is created upon the cross shaft. Geometric model made by Computer Added Design software packet is formed from simple geometrical shapes called geometric forms. The geometric model defines the real geometry of the considered element. The material of the all considered models in this paper is steel with following characteristic: elastic modulus  $E=2.07 \cdot 10^5$  MPa, Poisson’s ratio  $\nu=0.287$ .

The three dimensional tetrahedral discretization with density variation is done at first stage of numerical model generation. The zone of shape transition as zone of interest is discretized by the finite elements with smallest dimensions (Fig. 6) [9].

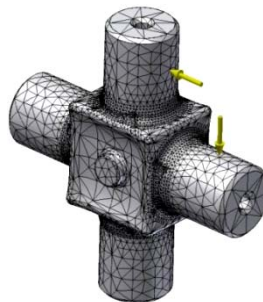

**Figure 6:** Discretization of numerical model

The border conditions are defined in according to theoretical considerations of stress state at cross shaft. The cross shaft is element with symmetry and four branches. The axes of the branches are in the same plain, forming the angle of  $90^\circ$  by them. The every branch is loaded by the same force transmitted from the yoke by the bearings. In the reference [4] numeric analysis is done for quarter of the cross shaft, only one branch loaded by one of the forces, but the numeric analysis in this paper is done for the whole cross shaft. The central zone is fixed and the each branch is loaded by the force in the interval from 30.3 kN to 52.8 kN and variations of stresses on the basis of the branches of the cross shaft are analyzed, as consequence of variation of operation angle  $\alpha_{12}$  and rotation angles  $\varphi_1$  and  $\varphi_2$ .

In order to numeric calculation has been done, it is necessary to repeat the procedure of structural analysis for every value of operation angle  $\alpha_{12}$ . The every analysis is done for different rotation position of shafts defined by rotation angle  $\varphi_1$  in interval between  $\varphi_1=0^\circ$  and  $\varphi_1=180^\circ$  due to symmetry of results from the position corresponding to half of the one rotation. Visualizations of results of calculations of stresses for different operating angles  $\alpha_{12}$  and different rotation angle  $\varphi_1$  are presented at Fig. 7, Fig. 8, Fig. 9, Fig. 10, Fig. 11 and Fig. 12.

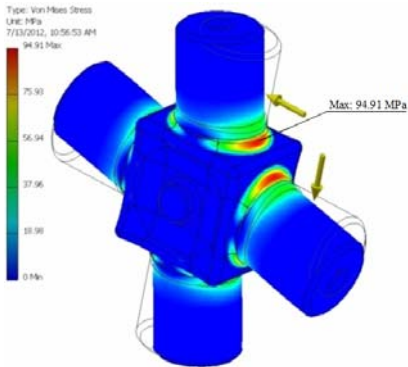

**Figure 7:** Numeric analysis of stresses at cross shaft for angles  $\alpha_{12}=10^\circ$  and  $\varphi_1=0^\circ$

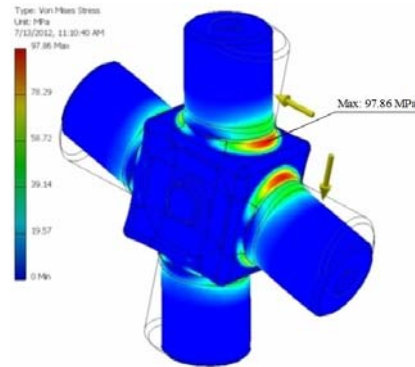

**Figure 8:** Numeric analysis of stresses at cross shaft for angles  $\alpha_{12}=10^\circ$  and  $\varphi_1=90^\circ$

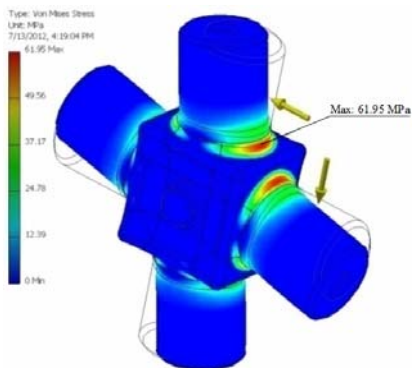

**Figure 9:** Numeric analysis of stresses at cross shaft for angles  $\alpha_{12}=50^\circ$  and  $\varphi_1=0^\circ$

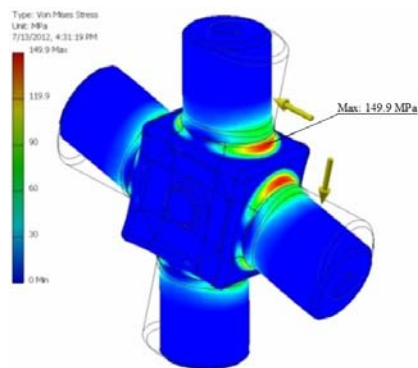

**Figure 10:** Numeric analysis of stresses at cross shaft for angles  $\alpha_{12}=50^\circ$  and  $\varphi_1=90^\circ$



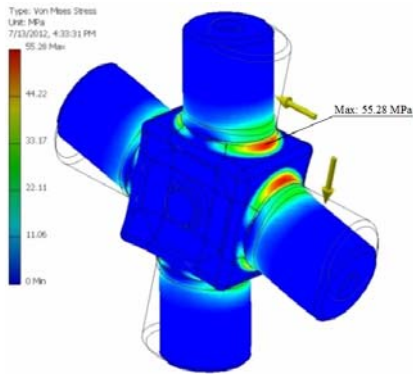

Figure 11: Numeric analysis of stresses at cross shaft for angles  $\alpha_{12}=55^\circ$  and  $\varphi_1=0^\circ$

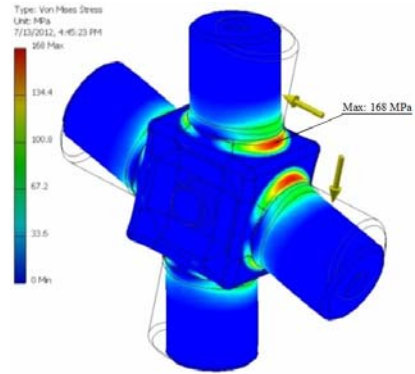

Figure 12: Numeric analysis of stresses at cross shaft for angles  $\alpha_{12}=55^\circ$  and  $\varphi_1=90^\circ$

### 3. GRAPHICAL PRESENTATION AND ANALYSIS OF CALCULATION RESULTS

The referent values of result stresses determined by analytic and numeric methods are presented at Fig. 13.

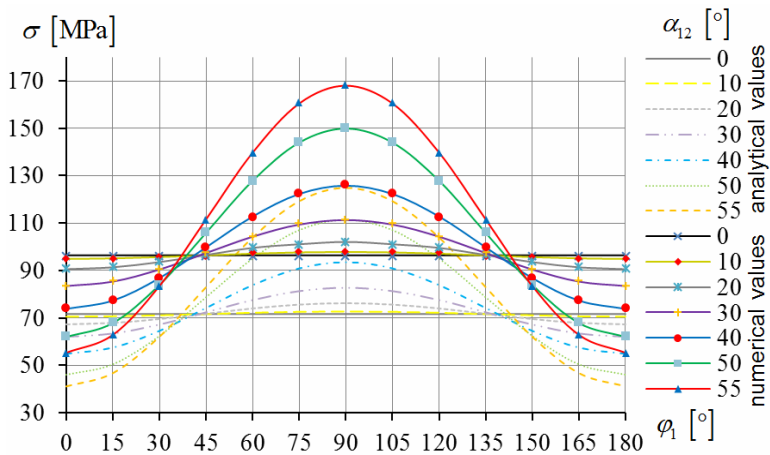

Figure 13: Results of analytical and numerical calculations of maximal stresses as functions of rotation positions

Referent analysis of result stresses obtained by analytic and numeric methods are based on values of relative variations expressed in % that are calculated in following form:

$$\Delta\sigma = \frac{|\sigma - \sigma^*|}{\sigma^*} 100 [\%], \tag{9}$$

where is:  $\Delta\sigma$  – relative variation of considered value,  $\sigma$  – value obtained by numeric method,  $\sigma^*$  – value obtained by analytic method. The compare presentation of relative variations of result stresses obtained by numeric method in relation to values obtained by analytic method is given at Fig. 14. To the aim of clear presentation of those variations every value from the considered interval of corresponding angle  $\alpha_{12}$  is divide by corresponding value that is obtained for rotation angle  $\varphi_1=0^\circ$ .

This presentation implicates that calculation of stresses by numeric method for different rotation angles have small differences from the values calculated by analytic method and that those differences are in allowable limits.

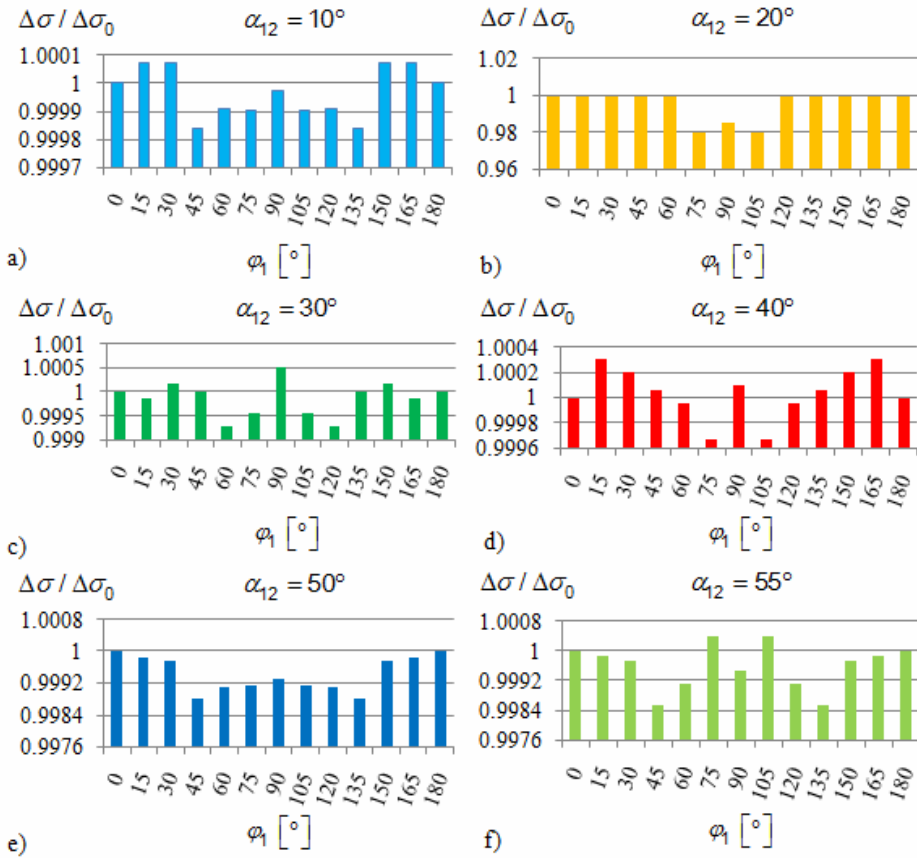

**Figure 14:** Variation of result stress for different values of angle  $\alpha_{12}$

The variation of result stress in function of variation of angles  $\alpha_{12}$  and  $\varphi_1$  are illustrated at Fig. 15.

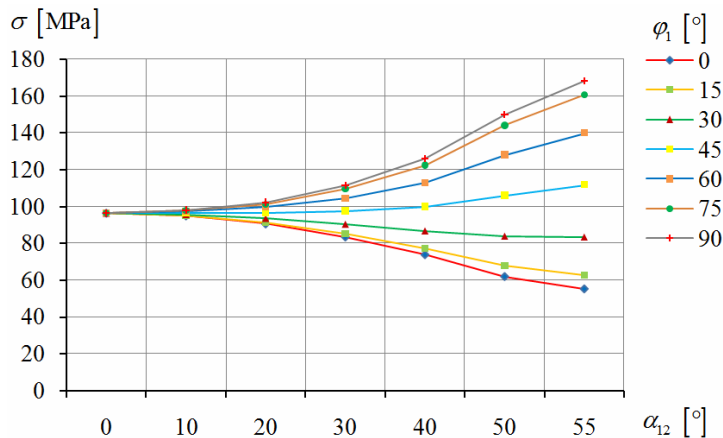

Figure 15: Variation of result stress in function of different values of angles  $\alpha_{12}$  and  $\varphi_1$

With increase of angle  $\alpha_{12}$  the result stress also increase but only for higher values of rotation angle  $\varphi_1$  ( $\approx 45^\circ$  and higher). For the angles  $\varphi_1$  smaller than ( $\approx 45^\circ$ ) the decrease of result stresses are induced. The presentation at Fig. 15 also implicate the identification of angles that cause severe variation of stresses and it is, by that, recommended to avoid exploitation of Cardan shafts with those values of operating angles.

## CONCLUSIONS

On the basis of the conducted analysis of the results the following conclusion can be done:

- Diagrams of stresses obtained by numeric and analytic method are of the same variation forms that implicate that established model for numeric analysis are done on the base of correct constructional solution and obtained results can be taken as relevant for further analysis in this area in order to minimize the stress level, so as for dynamic and fatigue analysis.
- Value of stresses obtained by numeric calculation are higher that results obtained by analytic method due to neglecting stress concentration for analytic method. The real shape transition zone from the central part to the branches at cross shaft is complex geometric form that provoked stress concentration and for precise determination of stresses the numeric analysis that considered real geometry must be done.

Maximal values of stresses are obtained for the operation angles  $\alpha$  between input and output shaft of  $\alpha_{12}=55^\circ$  and for rotation angle of  $\varphi_1=90^\circ$ .

On the basis of the conclusions it can be stated that both analytic and numeric method provide relevant results for analysis of stress variation due to changing of the input parameters, but special care must be put on problems of motion and relative positions of certain elements in exploitation. The influence of variation in positions of Cardan power

transmitter elements is significant to variation of stresses at critical cross section at the basis of the branches at cross shaft.

## ACKNOWLEDGMENTS

Financial support for the work described in this paper was provided by Serbian Ministry of Education and Science, project (TR35033).

## REFERENCES

- [1] Bayrakceken, H.; Tasgetiren, S. & Yavuz, I.: “Two cases of failure in the power transmission system on vehicles: A universal joint yoke and a drive shaft”, *Engineering Failure Analysis* 14, 2007, pp. 716–724, ISSN: 1350-6307
- [2] Humell, R. S. & Chassapis, C.: “Configuration design and optimization of universal joints”, *Mechanism and Machine Theory*, Vol. 33, No. 5, 1998, pp. 479-490, ISSN: 0094-114X
- [3] Humell, R. S. & Chassapis, C.: “Configuration design and optimization of universal joints with manufacturing tolerances”, *Mechanism and Machine Theory*, Vol. 35, 2000, pp. 463-476, ISSN: 0094-114X
- [4] Ivanović, L.; Josifović, D.; Živković, K. & Stojanović, B.: “Cross Shaft Design From the Aspect of Capacity”, *Scientific Technical Review*, Vol.61, No.1, 2011, pp. 48-53, ISSN: 1820-0206.
- [5] Ivanović, L., Josifović, D., Rakić, B. Stojanović, B., Ilić, A.: “Shape Variations Influence on Load Capacity of Cardan Joint Cross Shaft”, *The 7th International Symposium KOD 2012, Machine and Industrial Design in Mechanical Engineering*, 24 - 26 May 2012, Balatonfüred, Hungary, Proceedings, pp. 205-210
- [6] Jovičić, S., Marjanović, N.: “The basics of machine design”, Faculty of Engineering, University of Kragujevac, 2011, ISBN: 978-86-86663-81-8, Kragujevac (in Serbian)
- [7] Kojić, M.; Slavković R.; Živković, M. & Grujović, N.: “Finite Element Method I (linear analysis)”, Faculty of Mechanical Engineering, 2010, ISBN: 86-80581-27-5, Kragujevac (in Serbian)
- [8] Rathi, V. & Mandavgade, N. K.: “FEM analysis of universal joint of Tata 407”, *Second International Conference on Emerging Trends in Engineering and Technology, ICETET-09*, 2009, pp. 98-102.
- [9] Rakić, B.: “Modelling and simulation of power transmitter with Cardan joints”, Degree project, Faculty of Mechanical Engineering, 2011, Kragujevac (in Serbian)
- [10] Seher-Thoss, H. C., Schmelz, F., Aucktor, E.: “Universal joints and driveshafts: analysis, design, applications”, 2006, Birkhäuser, ISBN: 9783540301691
- [11] Tanasijević, S.: “Power transmitters”, *Yugoslav Tribology Society*, 1994, ISBN: 86-23-43041-7, Kragujevac (in Serbian)
- [12] <http://www.sdp-si.com/D757/couplings3.htm>, downloaded 14.07.2012